

NOR-LAKE, INCORPORATED
727 Second Street
Hudson, Wisconsin 54016

800-955-5253
715-386-2323
866-961-5253 Parts
800-388-5253 Service
715-386-4291 FAX
www.norlake.com



ICE CREAM TOPPING CABINETS - REFRIGERATED RAIL



PROJECT:
.....
ITEM NUMBER:
.....
MODEL NUMBER:
.....

SPECIFICATIONS FOR: REFRIGERATOR (ZR152SMS/0) & FREEZER (ZF152SMS/0)

- Exterior Finish: Exterior front, sides, doors, top and syrup rail are stainless steel. Exterior back and bottom are galvanized steel.
- Interior Finish: Cabinet and rail interior liners are smooth aluminum. Cabinet incorporates 1/4" radius covered corners for ease of cleaning.
- Dual Syrup Rail: The syrup rail is designed to accommodate 16 syrup jars. Syrup jars, pumps and lids are sold separate. The syrup rail meets NSF temperature requirements for holding hazardous food product and is controlled by a dedicated temperature control and power switch.
- Insulation: The cabinet and doors utilize foamed-in-place polyurethane insulation for added strength and energy savings.
- Hardware: Units come standard with one wire shelf per door adjustable in 1/2 inch increments, 4 casters and self-closing doors.
- Refrigeration These units incorporate a self-contained condensing unit in a dual circuit system to cool the cabinet storage section and the rail. The cabinet storage section and the rail have dedicated temperature controls to maintain proper temperature in the cabinet (+35°F to +40°F in ZR152 and -10°F to 0°F in ZF152) and rail (+33°F to +41°F in all models). The refrigerator base unit utilizes R-134a refrigerant and the freezer base utilizes R-404a refrigerant. The cabinet storage sections are automatic defrost with a condensate evaporator so no plumbing is required. The rail section is cold wall and has a dedicated power switch to shut it down when not in use. Rail should be shut off daily as well as when not in use for required defrost of the rail.
- Electrical: 115 volt, 60 HZ, 1 phase
- Approvals: UL, C-UL Safety** and UL Sanitation listed **

STANDARD FEATURES

- Air-cooled condensing unit
- Cold wall evaporator in rail
- Dedicated temperature controls for base & syrup rail
- Forced air evaporator in base
- Large surface work area
- Operating temperature of base: +38°F Refrigerator/ -10°F Freezer
- Polyurethane insulation
- Power switch for syrup rail
- Rigid solid base
- Side surface for pump station
- Stainless steel exterior
- 1 adjustable wire shelf per door
- 4 casters
- 15 cubic feet of base storage area
- Stocked for same-day shipment
- UL, C-UL Safety & UL Sanitation **
- Warranties: 2 year parts and labor, 5 year compressor

OPTIONAL FEATURES*

- 16 syrup jars with 7 hinged lids, 7 ladle lids & 2 pumps
- Legs in lieu of casters
- Rear shelf extension
- Syrup pump riser

* Most options are available one week from receipt of order. Please contact us for specific questions.
** C-UL is Underwriters Laboratories Safety Certification Mark which indicates that UL has tested the equipment to applicable CSA Standards.
*** UL Sanitation is Underwriters Laboratories Sanitation Mark which indicates that UL has tested the equipment to applicable NSF Standards.



Nor-Lake, Inc.
Registered to ISO 9001:2008
File No. 10001816

ICE CREAM TOPPING CABINETS

SPECIFICATION
GUIDE

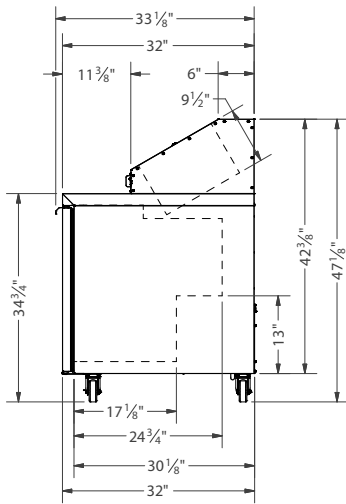

SIDE

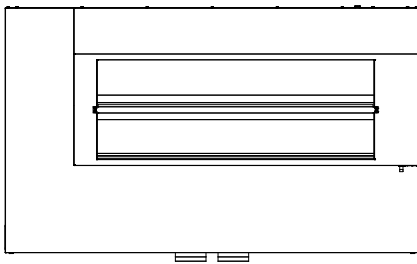

TOP
ZR152
ZF152

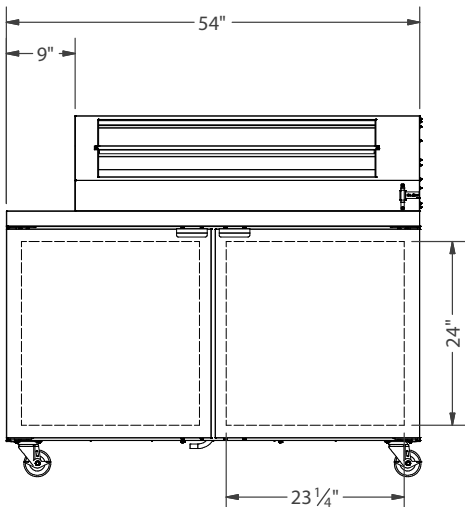

FRONT
ZR152
ZF152

SPECIFICATIONS

Models	ZR152 Refrigerator	ZF152 Freezer
<i>Crated Weight (lbs) (kg)</i>	350 (158)	350 (158)
<i>Crated Height (in) (cm)</i>	47 (118)	47 (118)
<i>Crated Width (in) (cm)</i>	59-3/4 (149)	59-3/4 (149)
<i>Crated Depth (in) (cm)</i>	36 (90)	36 (90)
<i>Interior Height (in) (cm)</i>	26 (65)	26 (65)
<i>Interior Width (in) (cm)</i>	50 (125)	50 (125)
<i>Interior Depth (in) (cm)</i>	24-3/4 (62)	24-3/4 (62)
<i>Overall Height (in) (cm)</i>	47-1/8 (118)	47-1/8 (118)
<i>Overall Width (in) (cm)</i>	54 (135)	54 (135)
<i>Overall Depth (in) (cm)</i>	33-1/8 (83)	33-1/8 (83)
<i>Gross Cubage (CuFt) (L)</i>	15.0 (425)	15.0 (425)
<i>Number of Shelves</i>	2	2
<i>Shelf Area (SqFt) (Sqm)</i>	14.5 (1.35)	14.5 (1.35)
<i>Number of Casters</i>	4	4
<i>Condensing Unit Size</i>	1/4 HP	1/2 HP
<i>Refrigerant</i>	R-134a	R-404a
<i>Electrical Characteristics</i>	115/60/1	115/60/1
<i>Cord & Plug Furnished</i>	Yes	Yes
<i>NEMA Plug Configuration</i>	5-15P	5-15P
<i>Total Amp Draw</i>	7.2	10.0

Specifications subject to change without notice.



Revision Date: 01/14
© 2014 NOR-LAKE, INC.
Printed in the U.S.A.
Part Number: 096187