

NORDKAPP



tritaggiaccio ice crushers



- Spacca ghiaccio professionale, strumento indispensabile nel bar per la preparazione di drink e frozen, e nel ristorante per l'esposizione di pesce o pietanze fresche.
 - Riduce in scaglie qualsiasi cubetto di ghiaccio prodotto da fabbricatore fino ad una misura di mm 40x40 a -3°C.
 - Previsto di regolazione sullo scarico, permette di gestire la grandezza media delle scaglie
 - Corpo macchina in alluminio estruso, bicchiere in acciaio inox, bocca di lavorazione in ABS alimentare e coltelli ghiaccio in acciaio.
 - Motore ventilato con trasmissione ad ingranaggi, per un servizio prolungato, micro interruttore sul coperchio per la massima sicurezza dell'operatore.
- Professional ice crusher, an indispensable bar tool for preparing drinks and frozen cocktails and in the restaurant for displaying fish or fresh foods.
 - Crushes any ice cubes made with an ice cube machine up to 40x40mm at -3° C.
 - Its discharge adjustment lets you regulate the average size of the crushed ice.
 - Extruded aluminium body, stainless steel container, food-grade ABS opening and s/steel blades.
 - Ventilated motor with gear transmission for prolonged use, micro-switch on the lid for maximum operator safety.



1. Leva per la regolazione dello spessore del ghiaccio
Adjustable lever ice thickness



2. Coltelli
Blades

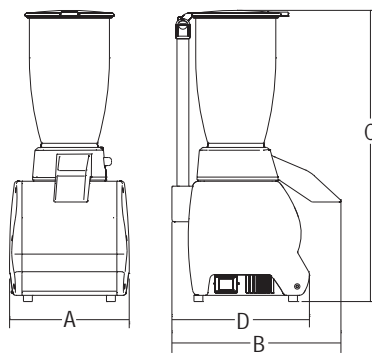

	Potenza Power Spannung Puissance	Alimentazione Power source Betriebsspannung Alimentation	Giri/coltello Blade speed Drehungen des Messer Tours lame	Capacità bicchiere Jug capacity Kapazität Capacité verre	Capacità vaschetta Capacity bowl Inhalt wanne Capacité bac	A	B	C	D	Peso netto Net weight Nettogewicht Poids net	Dimensioni imballo Shipping Verpack. abmessungen Dim. emballage	Peso lordo Gross weight Bruttogewicht Poids brut
	watt		r.p.m.	lt	lt	mm	mm	mm	mm	Kg	mm	kg
Nordkapp	150	230V 50/60 Hz F+N	800	3	2	205	285	491	235	5,2	410x280x560	8

	Potencia Potência Мощность 功率	Alimentación Alimentação Электропитание 電源	Vueltas cuchillos Giros lâminas Скорость вращения ножей 刀片转速	Capacidad vaso Capacidade copo Объём стакана 容量	Capacidad recipiente Capacidade recipiente Объём бункера 容量	A	B	C	D	Peso neto Peso líquido Вес нетто 淨重	Dimensiones embalaje Dimensões embalagem Размеры упаковки 包裝尺寸	Peso bruto Peso bruto Вес брутто 毛重
--	----------------------------------------	-----------------------------------------------------	-----------------------------------------------------------------------	----------------------------------------------------------	----------------------------------------------------------------------	---	---	---	---	----------------------------------------------	-------------------------------------------------------------------------	----------------------------------------------

